

STATE OF NORTH CAROLINA
DEPARTMENT OF TRANSPORTATION
HIGHWAY DIVISION 6

PLANS

Letting Date: March 20, 2019

CONTRACT ID: DF00259

TIP NO.: W-5706T

FEDERAL AID NO.: HSIP-1339(007)

WBS ELEMENT NO.: 44852.3.20

ROUTE NO.: SR 1339 (DEEP BRANCH ROAD)

LOCATION: FROM SR 1338 TO NC 711

COUNTY: ROBESON

LENGTH OF PROJECT: 19.289 MILES

TYPE OF WORK: SINUSOIDAL MILLED RUMBLE STRIPS AND PAVEMENT MARKINGS

**This electronic collection of documents is provided
for the convenience of the user
and is Not a Certified Document –**

**The documents contained herein were originally issued
and sealed by the individuals whose names and license
numbers appear on each page, on the dates appearing
with their signature on that page.**

**This file or an individual page
shall not be considered a certified document.**

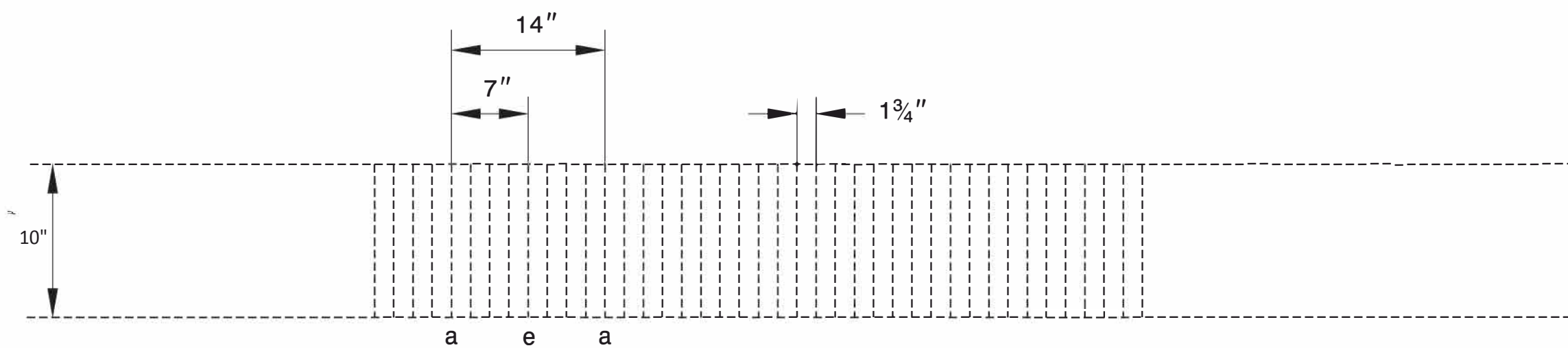

PLAN

LOCATION	DEPTH	
	MIL	INCHES
a	62.5	1/16"
b	156	5/32"
c	281	9/32"
d	438	7/16"
e	500	1/2"

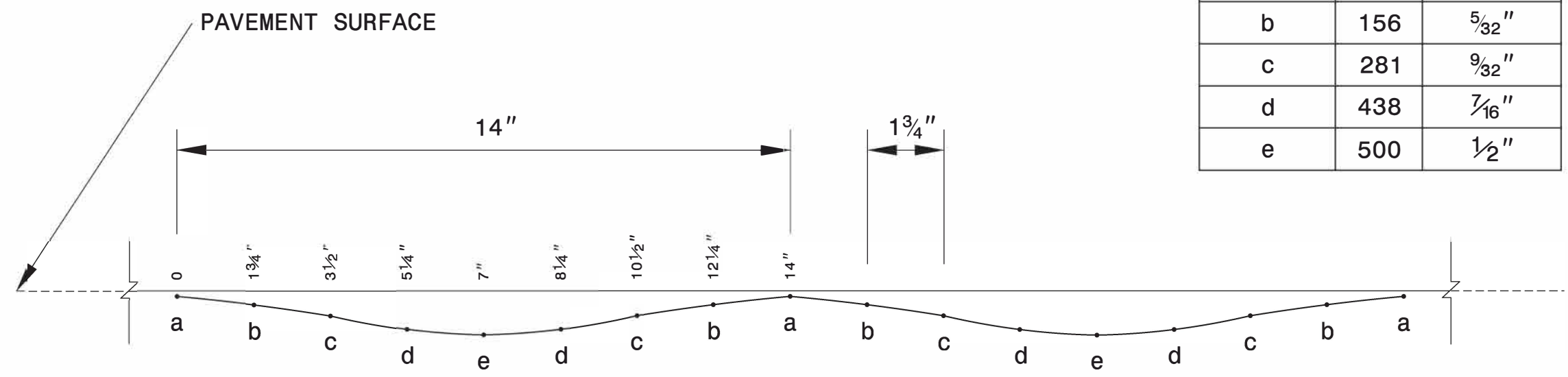

PROFILE

02-AUG-2017 14:46 S:\Contracts\Special Details\K Kempf\english\sinusodial rumble strips.dgn J:\overton AT_CSD-292996

CONTRACTS STANDARDS AND DEVELOPMENT UNIT
Office 919-707-6950 FAX 919-250-4119

SINUSOIDAL MILLED RUMBLE STRIPS

ORIGINAL BY: K.A.KEMPF DATE: 08/02/17
MODIFIED BY: DATE:
CHECKED BY: DATE:
FILE SPEC.: sinusodial rumble strips.dgn

